

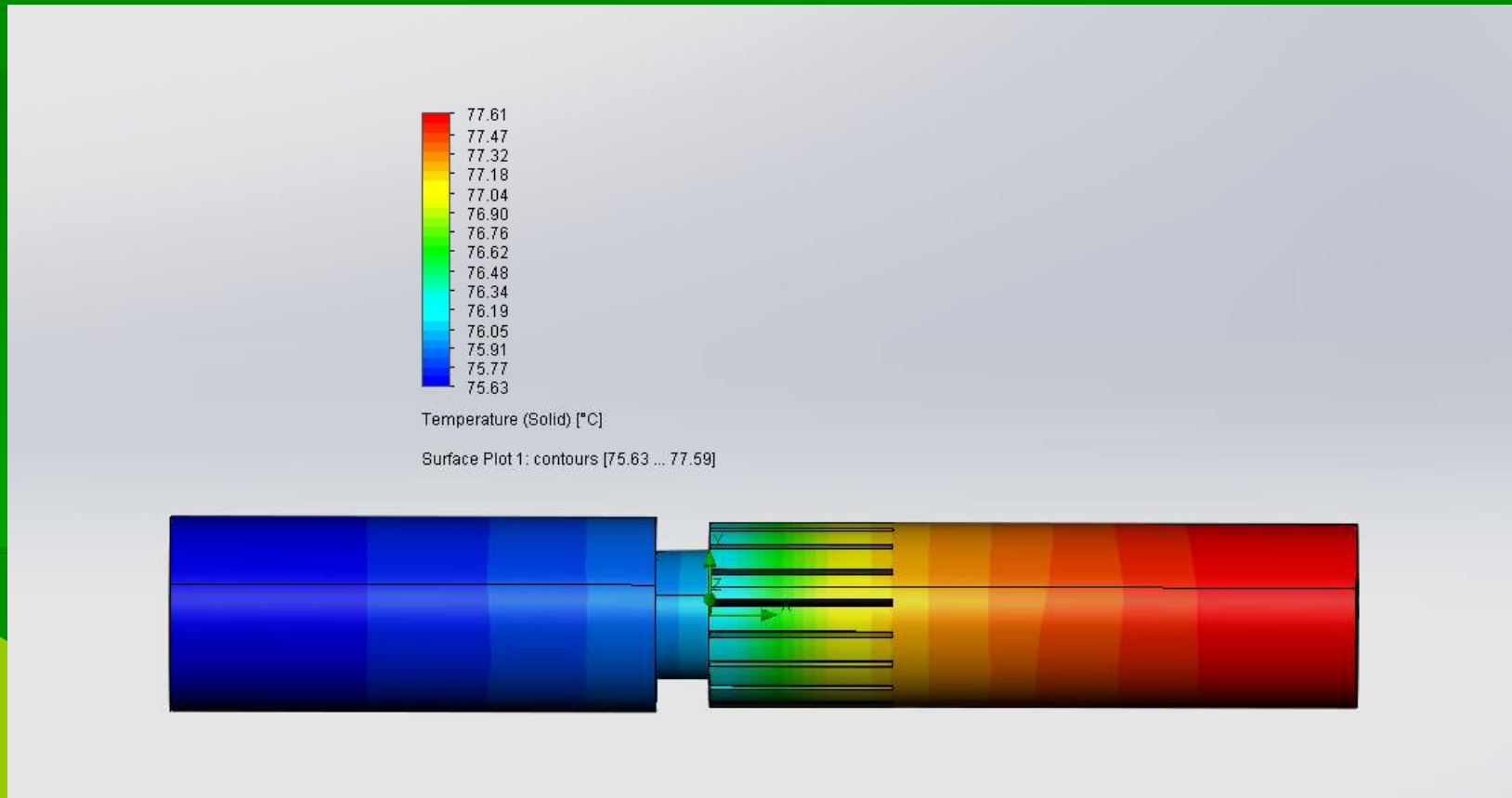

FEA 案例

产品性能分析：a,机械性能分析---强度分析，刚度分析，稳度/稳定性分析，疲劳分析，如正向力分析，插入力分 b,电气性能分析---电压，电流分析；c,电热分析---温升/散热分析.d,高频分析/SI分析



温升/热分析

www.encnn.com

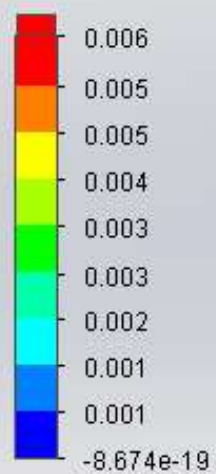

Voltage [V]

Surface Plot 2: contours

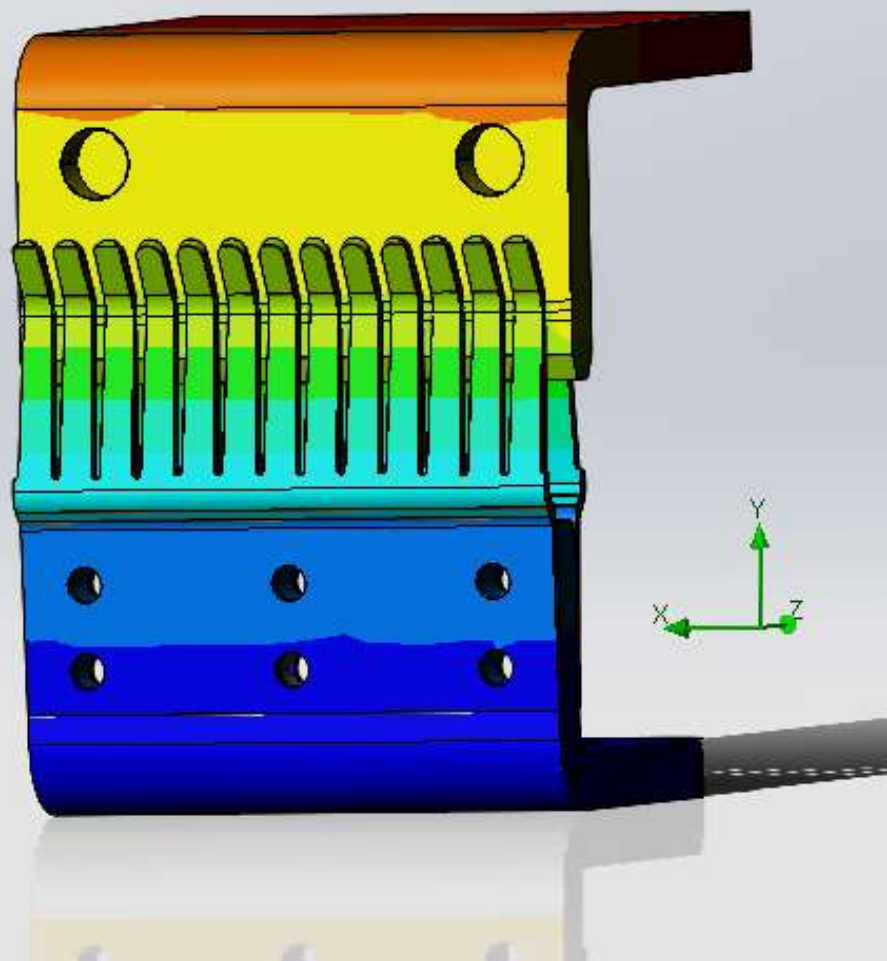

电压分析

www.encnn.com

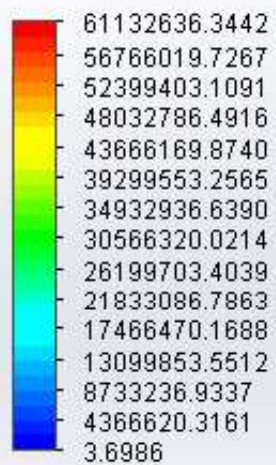

Electric Current Density [A/m²]

Cut Plot 1: contours [7.1069 ... 16735667.5298]
current density: contours

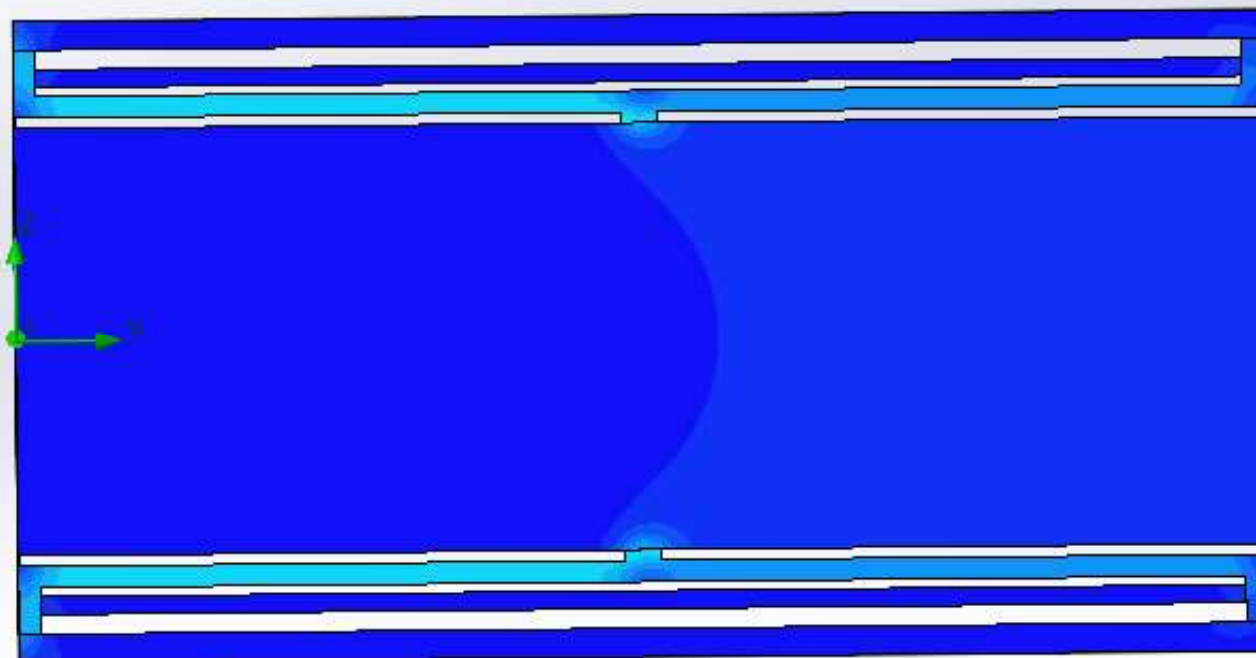



应力应变分析

www.encnn.com

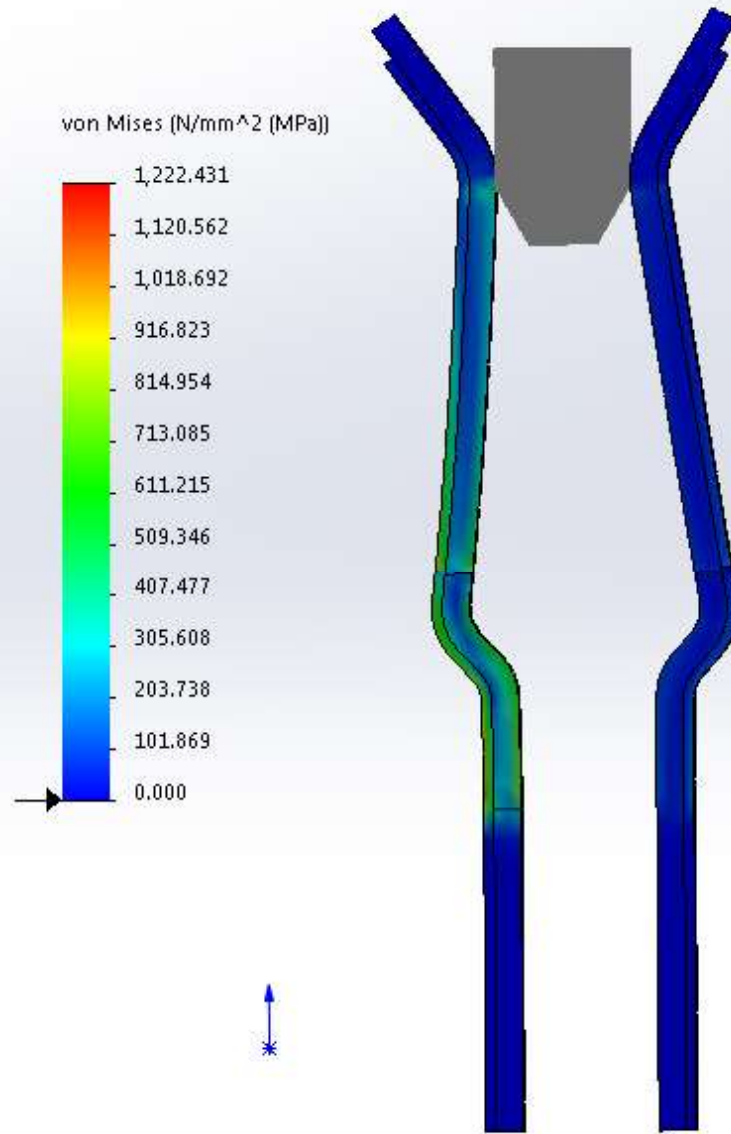



插拔力/正向 力分析

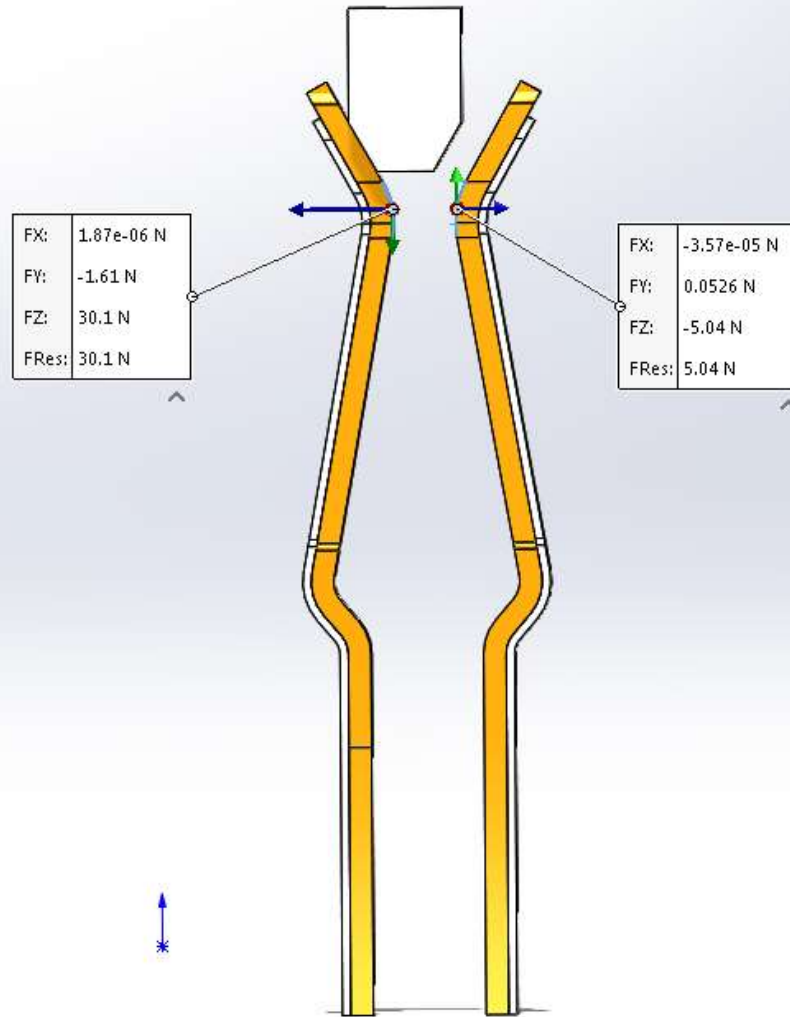



press fit: insertion force Vs displacement

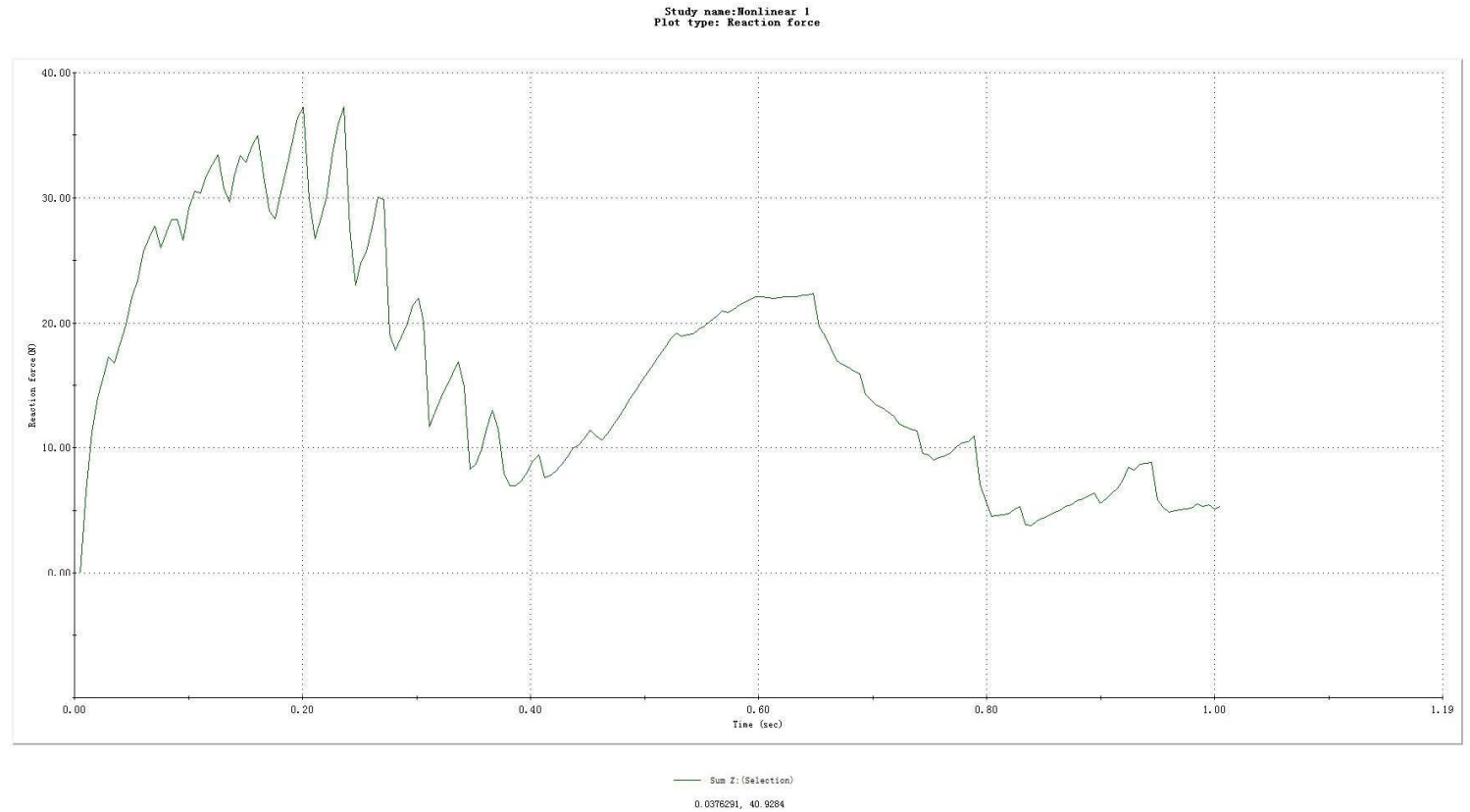
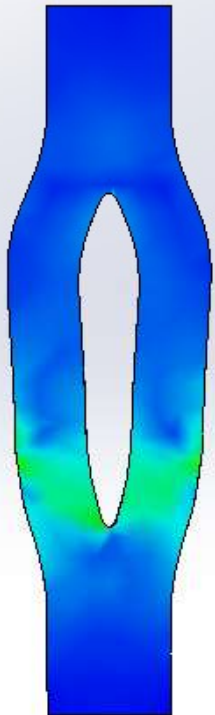

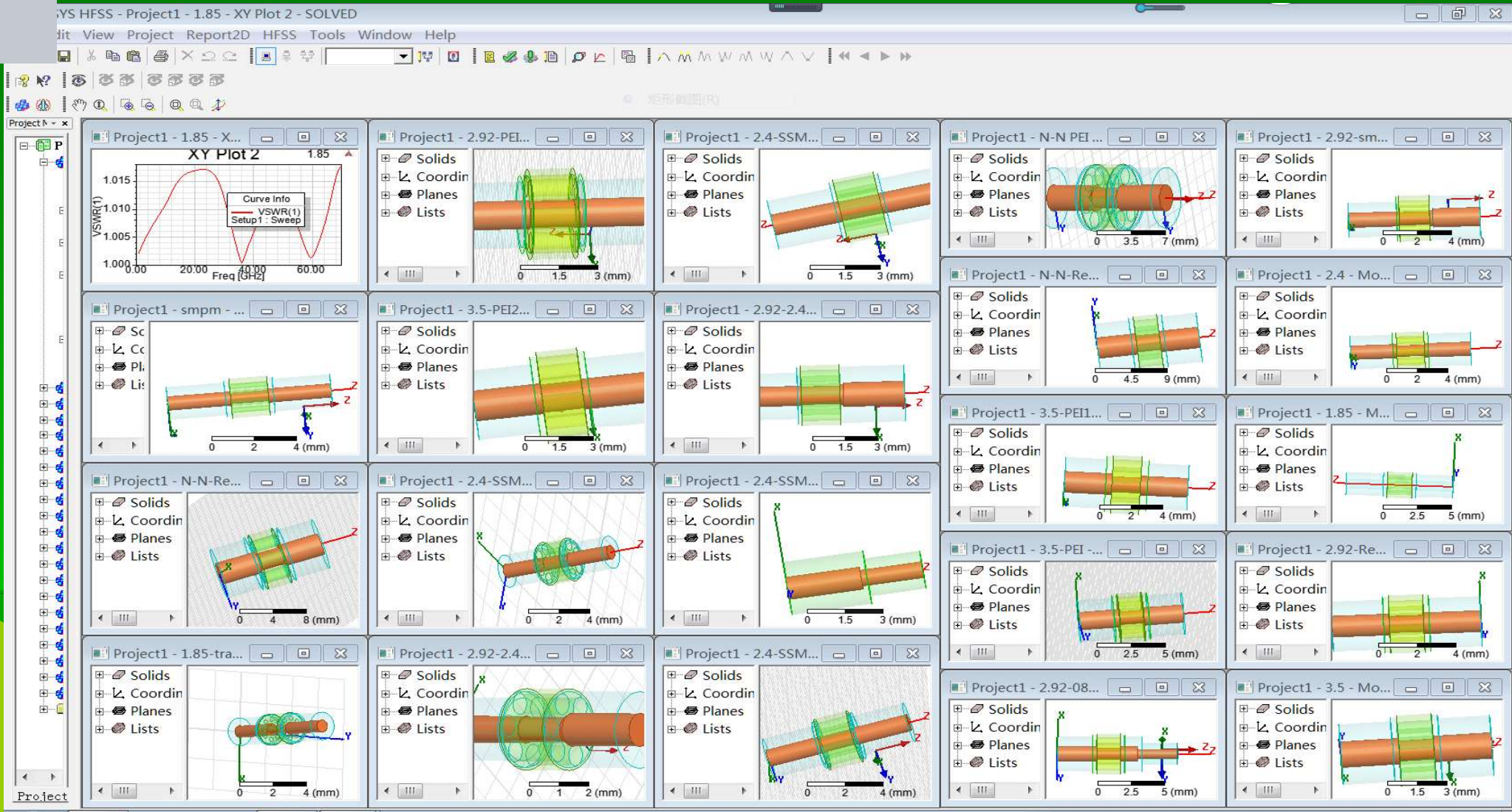

系列RF同轴产品分析

www.encnn.com

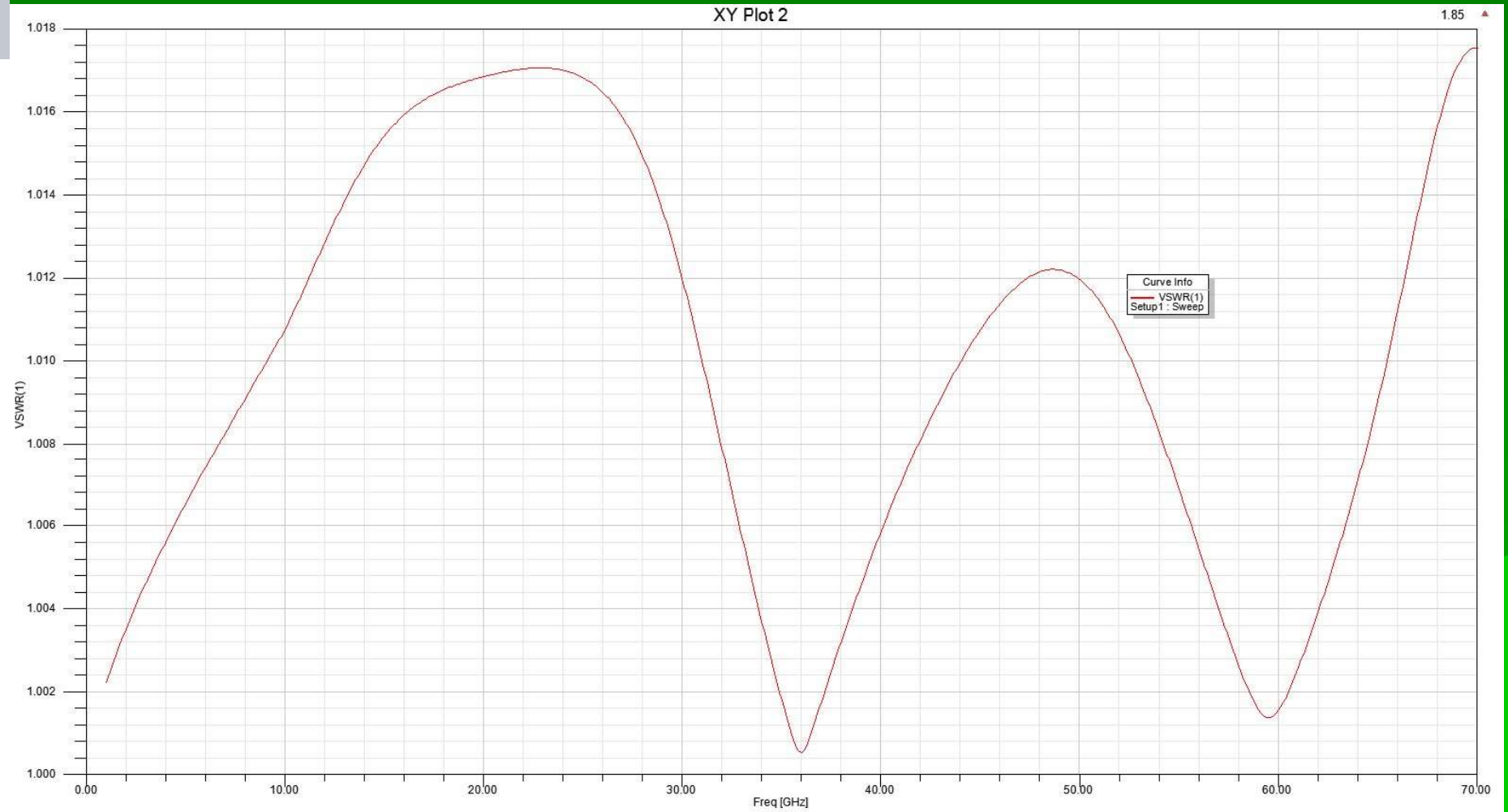

70GHz同轴产品分析结果

www.encnn.com



差分信号分析/信号完整性分析(SI).如回波损耗(RL),插入损耗(IL),串扰(crosstalk),差分共模转换(differential to common conversion),特性阻抗(characteristic impedance)

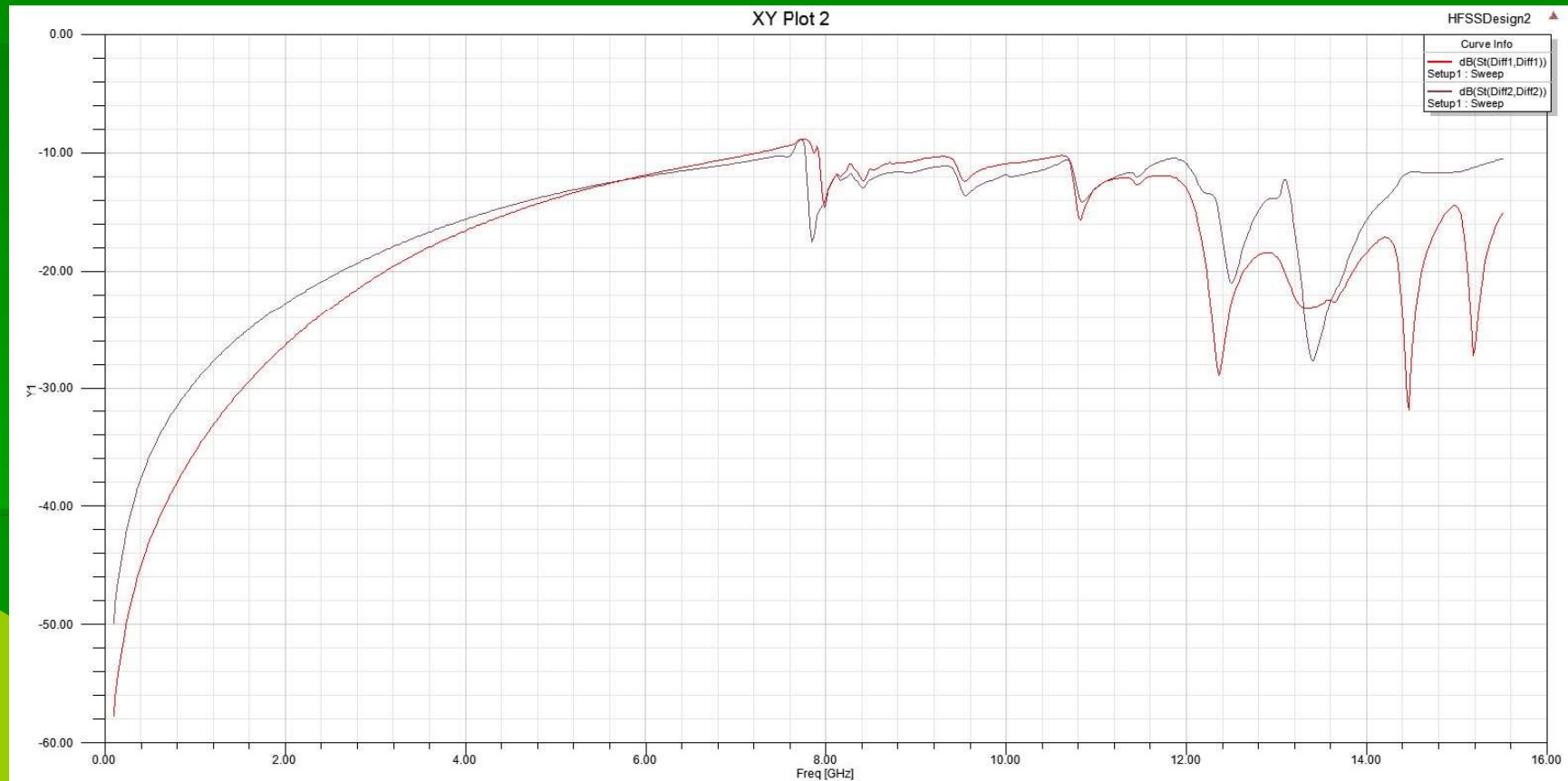

回波损耗(RL)

www.encnn.com



XY Plot 4

HFSSDesign2

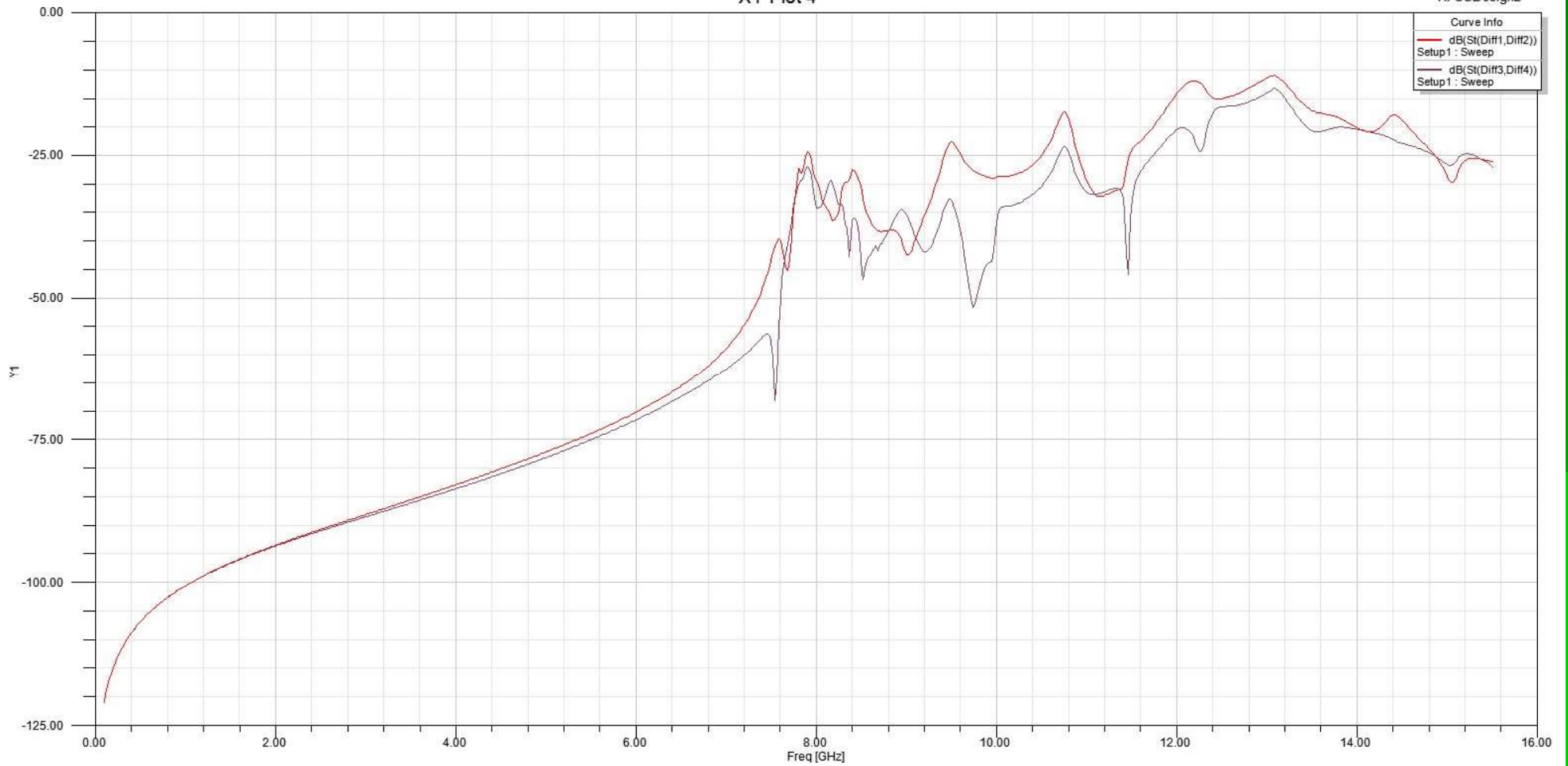

串扰(crosstalk)

www.encnn.com

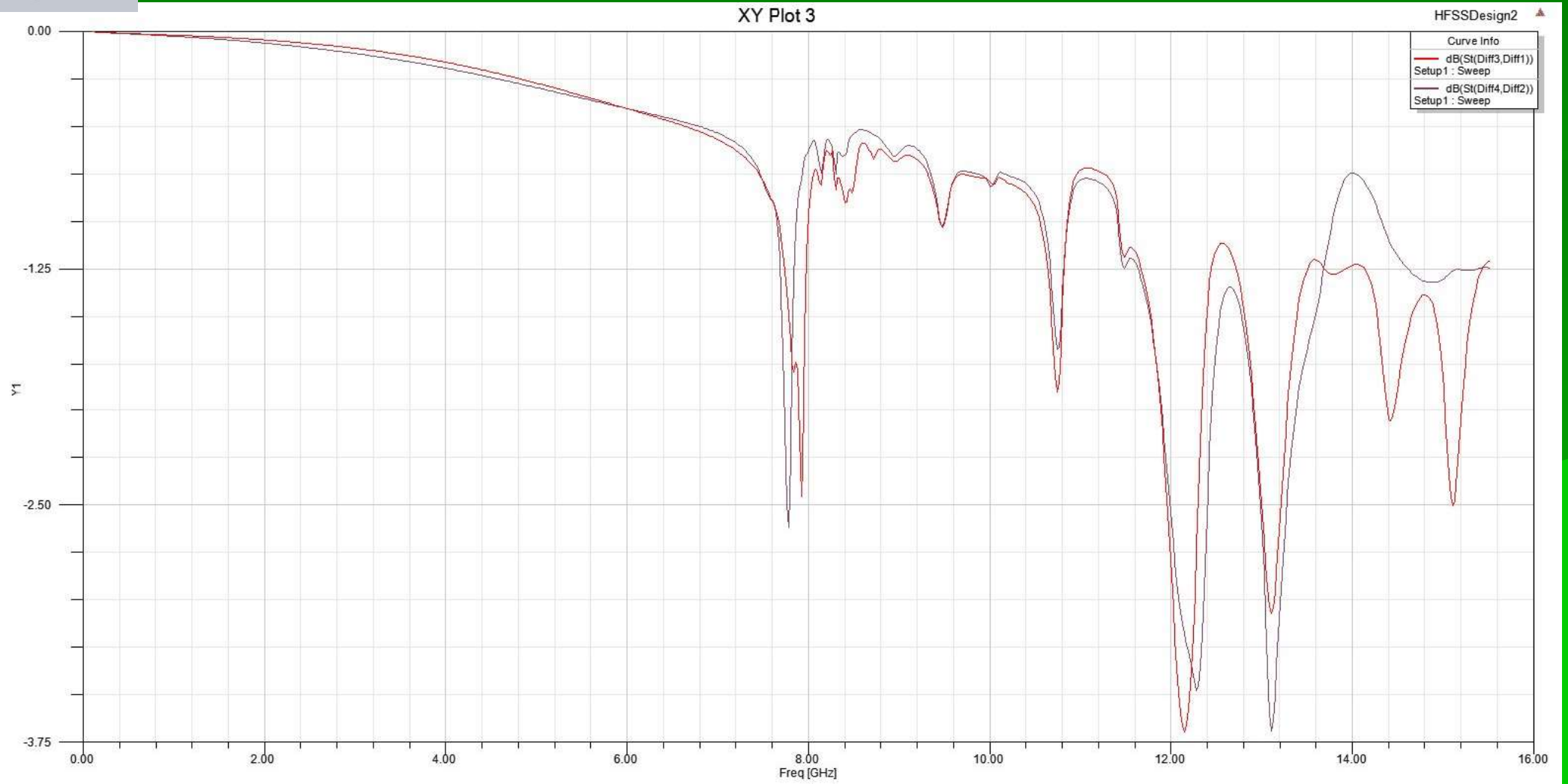

插入损耗(IL)

www.encnn.com

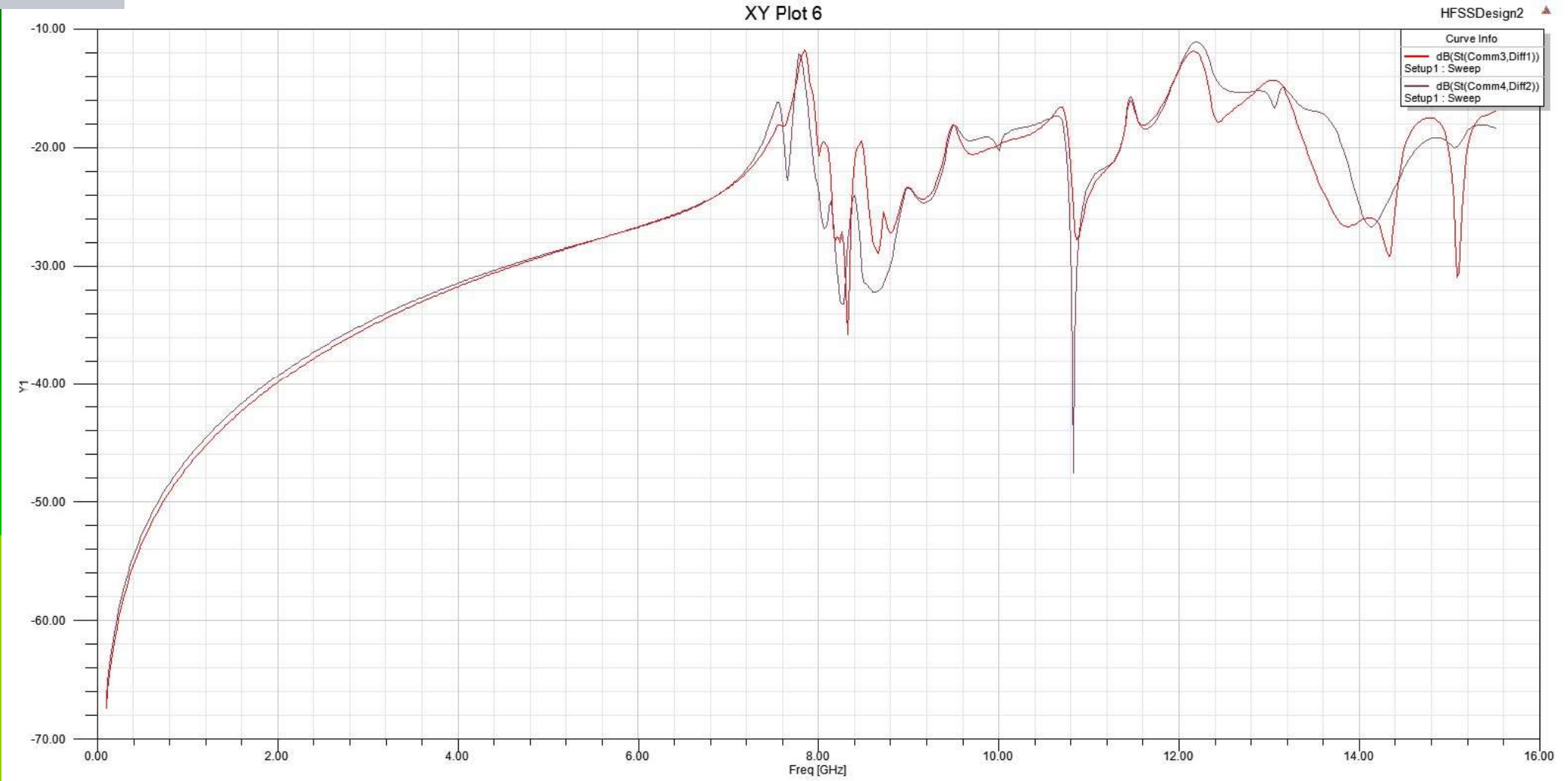

差分共模转换(differential to common conversion)

www.enchn.com

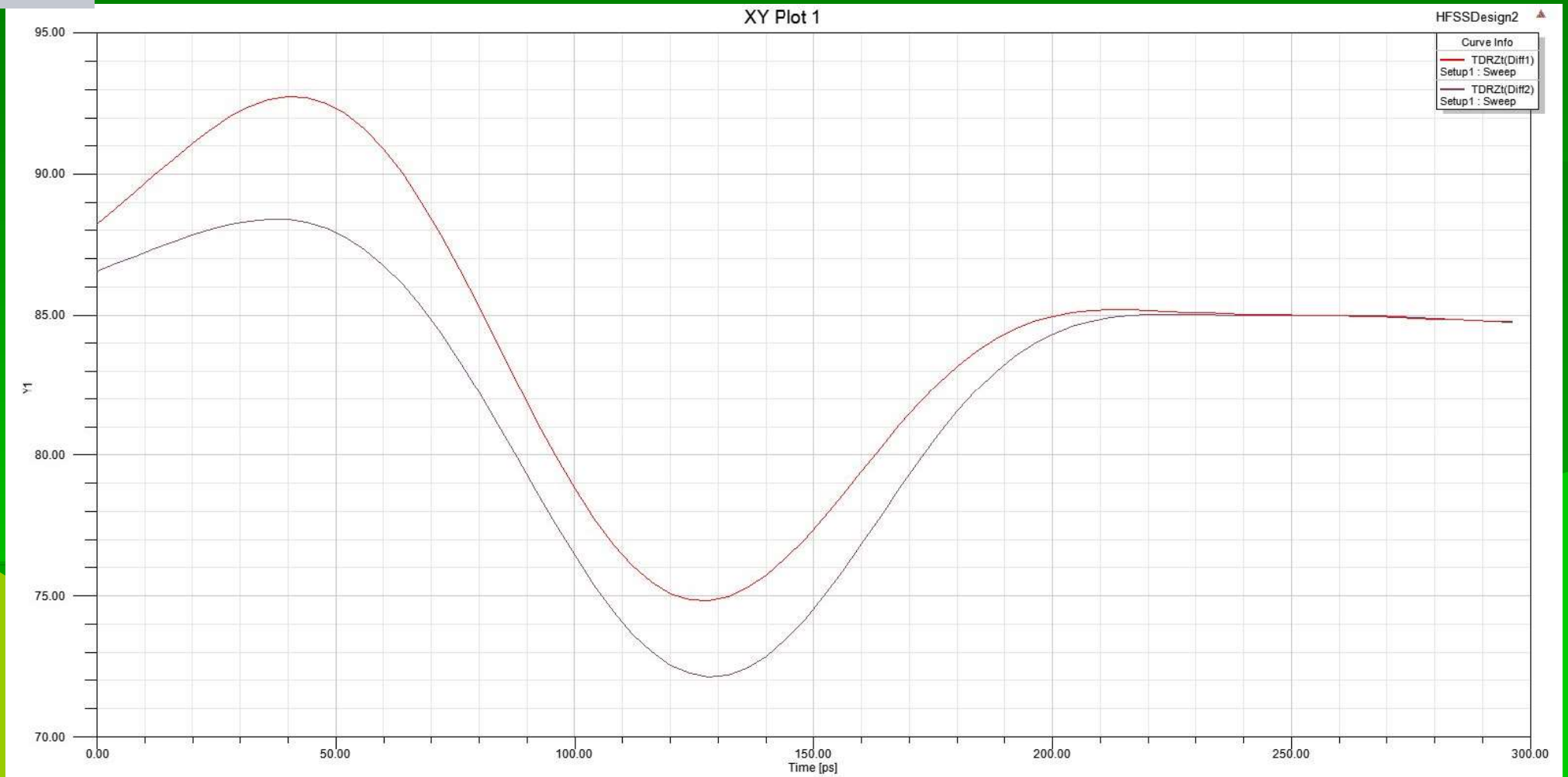

特性阻抗(characteristic impedance)

www.encnn.com